



# Crane Runway Steel vs Building Steel

You have a shiny new building with a shiny new crane and everything looks great. For some reason, though, the crane won't clear the building columns, even though the contractor and the crane manufacturer are saying everything is to spec and it's not their problem. Common sense says somebody is wrong and that somebody should have to pay (because it's going to cost a bundle). Unfortunately in this case, there's a giant crack in the building specs, and you've just fallen through it. This means that after all the arguing and legal costs, you're still going to have to pay to get it fixed. If you've already fallen in this black hole, there's not much you can do, but if you are about to embark on a new building with an overhead crane, this article will show you where the cracks are and suggest how to bridge them safely

## What Is Required?

The runway alignment specs—written by the Crane Manufacturers Association of America (CMAA) and adopted by the Metal Building Manufacturers Association (MBMA), the American Institute of Steel Construction (AISC), and the Association of Iron and Steel Engineers (AISE)—fill an entire page and take considerable time to interpret. A simplistic summary is that runways must be  $\pm 1/4$  inch in a single bay and no more than  $\pm 3/8$  inch over the full length of the runway.

These tolerances must be maintained in four ways: left/right, up/down, parallel to each other, and level in respect to each other. Figure 1 shows an actual AISC/ CMAA chart.

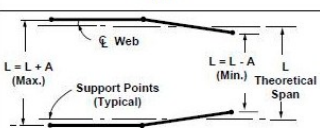
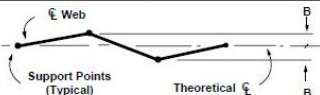
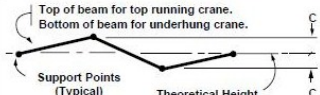
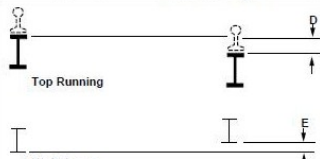
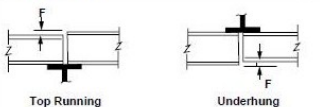
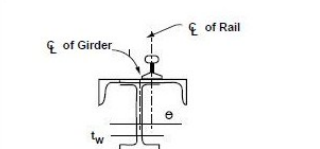
Runway Installation Tolerances			
Item	Figure	Overall Tolerance	Maximum Rate of Change
Span		$L \leq 50' A = 3/8"$ $L > 50' \leq 100' A = 1/2"$ $L > 100' A = 3/4"$	$1/4"$ in 20' - 0"
Straightness		$B = 1/2"$	$1/8"$ in 20' - 0"
Elevation		$C = 1/2"$	$1/8"$ in 20' - 0"
Rail-to-Rail Elevation		$L \leq 50' D = 1/4"$ $L > 50' \leq 100' D = 1/2"$ $L > 100' D = 3/4"$ $L \leq 50' E = 1/4"$ $L > 50' \leq 100' E = 1/2"$ $L > 100' E = 3/4"$	$1/8"$ in 20' - 0"
Adjacent Beams		$F = 1/2"$	N/A
Rail-to-Runway Girder Centerline		$e < 1/4 t_w$	$1/8"$ in 20' - 0"
Rail Separation	$\leq 1/4"$	N/A	N/A

A second set of crane-related numbers to remember are the crane-to-building tolerances. CMAA and the Occupational Safety and Health Administration (OSHA) require that all moving objects (the crane and hoist) must clear all stationary objects (the building) horizontally by 2 inches and clear all vertical objects (roof trusses, lights, pipes, etc.) by 3 inches. Although this meets the legal requirements, this author highly recommends the horizontal be increased to 4 inches and the vertical to 6 inches to allow for unforeseen problems.

## Where's the Villain?

As in a detective story, the first move is to round up the suspects. The problem can be found in one of four areas:

1. Mill steel tolerances
2. Building steel fabrication tolerances
3. Building erection tolerances
4. Overhead crane runway tolerances (measuring and verification methods)

One big problem is that runways usually are built with building steel (wide flanges), fabricated by



building steel fabricators, and installed by building steel erectors, but runway steel is not building steel. In fact, building steel and runway steel are incompatible in the first three ways listed previously. Following is an illustration of just the first point—mill steel tolerances—but the other two items exhibit similar shortcomings. The mill tolerance for structural wide-flange beams basically is 1/8 inch per 10 feet of length, although this oversimplifies the American National Standards Institute (ANSI)/AISC specification somewhat (see Figure 2).

<b>W Shapes, HP Shapes</b>			
<b>Other Permissible Variations</b>			
Area and weight variation: ±2.5 percent theoretical or specified amount.			
Ends out-of-square: 1/4 in. per in. of depth, or of flange width if it is greater than the depth.			
<b>Camber and Sweep</b>			
Sizes	Length	Permissible Variation, In.	
		Camber	Sweep
Sizes with flange width equal to or greater than 6 in.	All	$\frac{1}{8} \text{ in.} \times \frac{(\text{total length ft.})}{10}$	
Sizes with flange width less than 6 in.	All	$\frac{1}{8} \text{ in.} \times \frac{(\text{total length ft.})}{10}$	$\frac{1}{8} \text{ in.} \times \frac{(\text{total length ft.})}{5}$

Source: Copyright © American Institute of Steel Construction, Inc. Reprinted with permission. All rights reserved.

Therefore, in a common 30-foot bay, the wide-flange beam can have a sweep (horizontal bow) of 3/8 inch, which means that putting up this first piece of steel exceeds the acceptable CMAA/MBMA/AISC runway tolerance already. To compound the problem, the opposing runway can have an equal (but opposite) sweep, doubling the problem.

### Solutions

How should this seemingly simple problem be addressed? Three potential solutions exist:

1. Adjust the rail laterally in relation to the girder. Although this solution is the most commonly used, it is bad engineering practice and actually is prohibited by the AISC specifications. The runway beam/girder is the wide-flange structural shape that supports the runway, while the rail (commonly American Society of Civil Engineers (ASCE) rail, similar to railroad rail) is the track upon which the end truck wheels traverse (see Figure 3). It is a common misconception that the runway beams have no particular installation tolerance and that only the rail is at issue. Further, this assumption seems to be confirmed by the lateral adjustment of the rail fasteners (for example, J-bolts/ hook bolts or patented clips). Actually, the tolerance of the beam installation is governed by the tolerance of the rail installation. This is because, according to AISC Design Guide 7, paragraph 19a, the centerline of the rail should be within ±3/4 inch of the girder web thickness. This prevents top flange rollover and subsequent fillet cracking and possibly girder failure.

This conventional wisdom is so commonly accepted that it has evolved into generally accepted practice. Unfortunately, like so much conventional wisdom, it's wrong, it's bad for the equipment, it will result in significantly shorter service life, and it can be dangerous.

2. Augment the specs. Just because the generally accepted specs have left the crane runways as an orphan does not mean that you as a prospective new building owner should not include a stop-gap page of specs to cover yourself. If you buy the steel from the same vendor, fabricate with the same fabricator, and install with the same installation crew, you very likely will end up with the same problem. It defies reason that any efficient contractor can buy, fabricate, and install 20+ pieces of apparently identical red primed steel to a tolerance two to four times tighter than the other several thousand pieces of red



steel in that same building. This is not meant to slight building contractors.

Successful contractors have set up a well-disciplined system to produce and install building steel, but runway steel, although similar-looking, is a significantly different animal. While it is unlikely the contractor would adopt this more stringent standard temporarily, it is not impossible.

The silver lining for you, the buyer, in using the augmented specs as part of the contract is that the corrections no longer are your problem or expense.

3. Redefine the scope of building contractor and crane supplier responsibilities. This technically correct, practically viable solution is the least used of the three, simply because of lack of knowledge and higher up-front costs. The common scope of the crane builder's contract is to supply and install the crane, runway rail, and conductor bar. This leaves a critical gap in which the buyer is exposed to the previously mentioned problems. The scope should be changed to move responsibility for the runway girders from the building contractor to the crane builder. Chances are, the crane builder will insist on very tight tolerances from the steel supplier and will take precautions to account for reasonable floor and column tolerances. Also, having the crane builder's employees install the runways can help to improve installation accuracy because this job is their specialty. If the plant is a union plant, however, the runway conductor bar installation should be awarded to a local electrical contractor, while the crane builder remains responsible for the bar.

## Get It Right the First Time

In summary, runway steel is not building steel. Poor runways will result in premature wheel failure, motor and or gearbox failure, and premature runway replacement. With a typical wheel replacement costing \$8,000 and new runways costing \$50,000 or more, not to mention downtime, getting it right the first time can be a real bargain. Using augmented overhead crane runway specs in conjunction with the information provided here can help you to stay out of court and maintain good relations with valuable vendors.

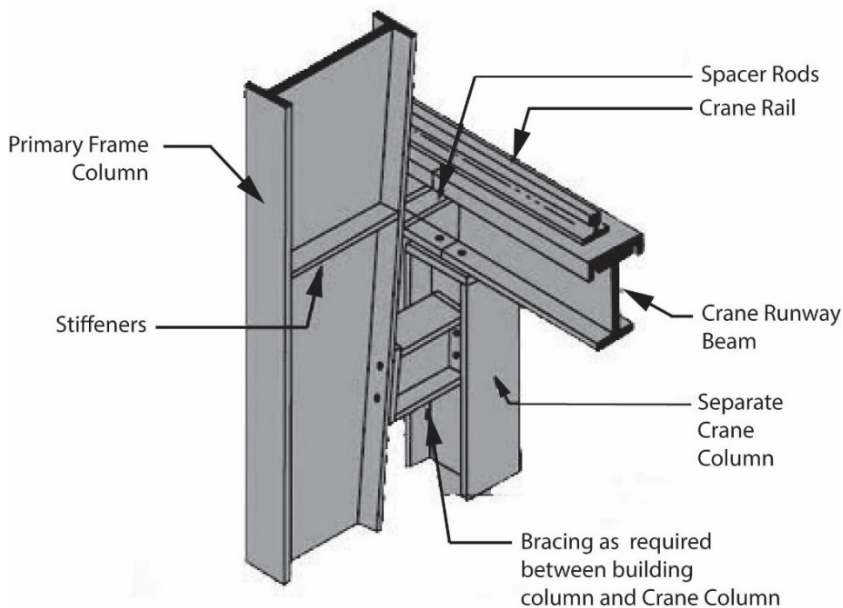

Figure 3

*The runway beam/girder is the wide-flange structural shape that supports the runway, while the rail is the track upon which the end truck wheels traverse.*

Source: <http://structuralofengineering.blogspot.ca/2010/08/avoiding-pitfalls-in-crane-projects.html>

Structural Engineering, Labels, Overhead Crane, Structural Model, Structural Testing

Posted by hery